

BOURNS®

Features

- Board mount
- 330 V surge protector
- UL Recognized
- Economical, reliable choice for all paired copper communications circuits
- Solid-state responsiveness combined with robust GDT

Applications

- Telecommunications
- High speed data networks
- Hybrid fiber-coax networks
- Broadband powered networks

MSP® Series - Multi-Stage Protector Sub-Assembly

Bourns® MSP® Multi-Stage Protector Series is a new generation of telecommunications protector designed to be the best all-around protection choice on both today and tomorrow's copper pair based communications circuits. It combines the strengths of gas tube and solid-state protectors while eliminating their weaknesses. Bourns® MSP® Multi-Stage Protector series is the synergistic integration of three advanced protection technologies; sixth generation gas tube, precision matched MOVs, and switch-grade fail-short. Working together, these three technologies meet the challenges of the evolving high-speed network.

Bourns® MSP® Series can be used universally on POTS, ISDN, ADSL, SDSL, HDSL, RADSL, VDSL, 10BaseT, and T1 carrier. Bourns® MSP® Series is the most economical, reliable, and best performing choice for all paired copper communications circuits.

Characteristics

Test Methods per IEEE C62.31, UL 497, CSA C22.2, Telcordia GR 1361 and applicable sections of Telcordia GR 974.

Characteristic	Model No.
	2026-33-CxM143
DC Breakdown @ 100-2000 V/s	300 to 400 V
AC Breakdown @ 60 Hz	300 to 400 V
Impulse Breakdown	
100 V/μs	600 V
1000 V/μs	650 V

Insulation Resistance	100 Vdc	> 1 GΩ
Insertion Loss	10 MHz	0.01 dB
Capacitance Line to Line.....	1 MHz	10 pF typical
Capacitance Line to Ground	1 MHz	20 pF typical
Impulse Reset (DC Extinguishing)	52 V, 260 mA	< 10 ms
	135 V, 200 mA	< 10 ms ¹
Impulse Life Characteristics	100 A, 10/1000 μs	> 3000 operations ²
	300 A, 10/1000 μs	> 1000 operations ²
	500 A, 10/1000 μs	> 1000 operations ³
	2000 A, 10/250 μs	> 100 operations ²
	5000 A, 20/100 μs	> 10 operations ²
	5000 A, 10/350 μs	1 operation ⁴
	20000 A, 8/20 μs	> 10 operations ^{2,4}
AC Life Characteristics.....	0.5 A rms continuous	> 30 seconds
	1 A rms, 1 second, 600 ft. cable	> 60 operations
	1 A rms, 1 second, 1 mile cable.....	> 60 operations
	10 A rms, 1 second	> 20 operations
	65 A rms, 11 cycles	> 1 operation ³
	120 A rms, 0.1 second	1 operation
Life Test Criteria.....	Insulation Resistance Throughout the Life Test	100 MΩ
	Life Test Failures.....	0.0 %
	Failures During Environmental Cycling w/Surges	0.0 %
Fail-Short (vented or non-vented gas tube).....		> 30 A rms, simultaneously
Operation and Storage Temperature.....		-55 to +85 °C
Climatic Category (IEC 60068-1).....		40/90/21

Notes:

- **UL, cUL Listed. File E153537**
- Line to Line voltage is approximately 1.8 to 2 times the stated Line to Ground breakdown voltage.
- At delivery AQL 0.65 Level II, DIN ISO 2859.
- ¹ Surpasses Telcordia GR 974 (network applied).
- ² Exceeds Telcordia GR 1361.
- ³ RUS (REA) PE-80.
- ⁴ Total current equally divided between each line to ground.

*RoHS Directive 2002/95/EC Jan 27, 2003 including Annex.

Specifications are subject to change without notice.

Customers should verify actual device performance in their specific applications.

How to Order / Product Dimensions

2026-33-C2M143

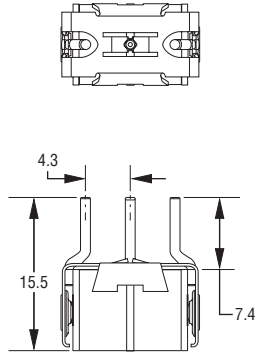

2026-33-C16M143

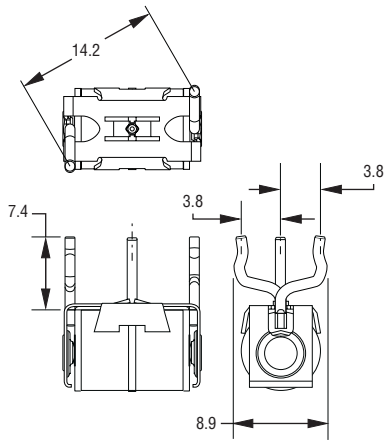

2026-33-C4M143

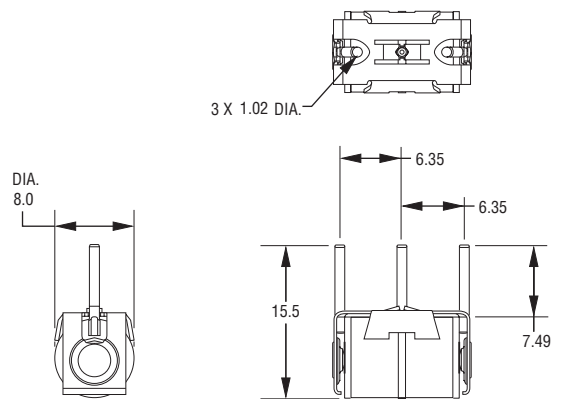

DIMENSIONS = MILLIMETERS

Contact factory for custom configurations.